



MOUNTING NUTS

Stud Nut

Part Number	Across Flats	Nut Thickness	Nut (Thread)
<u>N10-18</u>	15/16"	3/8"	5/8-18

Rod Nut

Part Number	Across Flats	Nut Thickness	Nut (Thread)
<u>N04-28A</u>	7/16"	5/32"	1/4-28
<u>N04-28B</u>	3/8"	1/8"	1/4-28

CB-1795

Clevis Bracket
Material: Steel, bright zinc plated

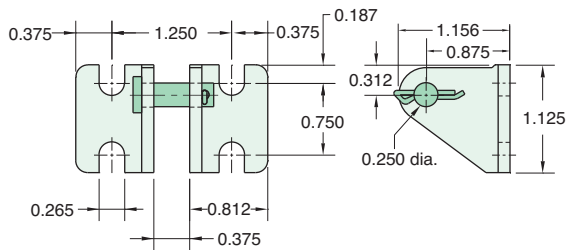

RC-1281

Rod Clevis
Material: Steel, electroless nickel plate

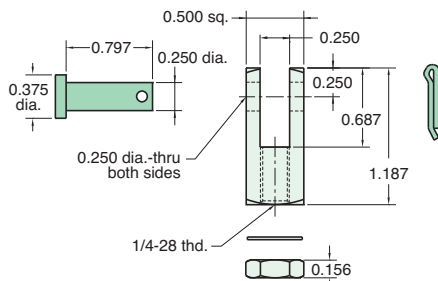

RE-1285

Rod End
Material: Steel, bright zinc plated body

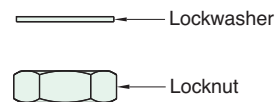
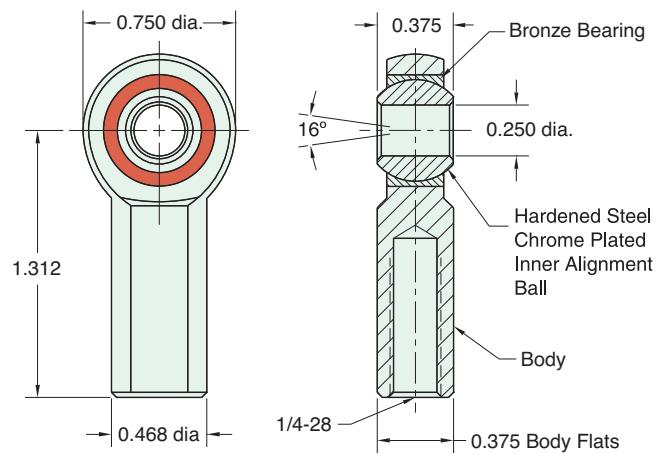

Max. Static Radial Load (rod end only): 2,545 lbs.
Fits Rod Thread Size: 1/4-28

FB-1791

Foot Bracket
Material: Steel, bright zinc plated

